

## OPERATING MANUAL

## Tank Monitor TCS



Thank you for buying the Tank Monitor TCS. This digital unit is state of the art in Tank monitoring.

### You recognize at a glance:

- the current filling levels of up to 4 tanks
- the current voltages of up to 2 battery banks

### You have the possibility of adjusting an alarm threshold

- for each tank (full or empty alarm)
- for each battery bank (under or over voltage)

philippi elektrische systeme gmbh  
Neckaraue 19  
D-71686 Remseck am Neckar

www.philippi-online.de  
info@philippi-online.de  
Tel: +49 (0)7146/8744-0,Fax-22

## 1 General Information

### 1.1 Purpose

The tank monitor TCS can only be operated with low voltage DC 8-32V. It is designed for use on yachts and may only be operated in closed rooms that are protected from rain, humidity, dust and condensation. Never use the tank monitor TCS in places where there is a risk of explosion due to gas or dust. The tank monitor is not suitable for outdoor installation.

### 1.2 Scope of delivery

- Tank Monitor TCS
- 1 Plug-in terminal (MCVR 1,5- 11-pole)
- 1 fuse holder ASH1 incl. fuse FSS 1A
- This operating manual

### 1.3. Recommended sensors (to be ordered separately)

To measure the fluid level, we recommend the immersion tube sensors of the TGT or TGW series for fuel and fresh water as well as the ultrasonic sensors UTV for waste holding tanks. Please use for deeper tanks up to 200 cm and very precise measurements the pressure sensor TDS200 (water/diesel/grey/black water) or TDN200 (water).

However, these sensors are not included in the scope of delivery.

Sensors from other manufacturers can also be connected.

The monitor is configured in the SETUP to the connected sensors. It is also possible to adapt it to the tank geometry in order to display the actual tank contents correctly.

Please note: the liter display is only a conversion of the measured filling level and can never be liter-specific depending on the accuracy of the measurement!

#### **Fresh water:**

- |                   |             |                        |
|-------------------|-------------|------------------------|
| • Floater sensor  | TGW 200-800 | Order no.: 6 6011 7xxx |
| • Pressure sensor | TDN 200     | Order no.: 6 6025 1208 |

#### **Gasoline:**

- |                  |              |                        |
|------------------|--------------|------------------------|
| • Floater sensor | TGT 200-1000 | Order no.: 6 6011 7xxx |
|------------------|--------------|------------------------|

#### **Diesel/Fuel:**

- |                   |              |                        |
|-------------------|--------------|------------------------|
| • Floater sensor  | TGT 200-1000 | Order no.: 6 6011 7xxx |
| • Pressure sensor | TDS 200      | Order no.: 6 6026 1206 |

#### **Grey / black water:**

- |                     |           |                        |
|---------------------|-----------|------------------------|
| • Pressure sensor   | TDN 200   | Order no.: 6 6025 1208 |
| • Ultrasonic sensor | UTV 20-80 | Order no.: 7 0219 35xx |

*recommended accessories for ultrasonic transmitters:*

- |                                                           |                      |                        |
|-----------------------------------------------------------|----------------------|------------------------|
| • Focus tube                                              | UFT 40 (length 40cm) | Order no.: 7 0219 9400 |
| • Focus tube                                              | UFT 80 (length 80cm) | Order no.: 7 0219 9800 |
| • Distance ring                                           | UTS 25 (25mm high)   | Order no.: 7 0219 9025 |
| • fuse holder ASH1A incl. fuse FSS 1A for measuring lines |                      | Order no.: 6 0030 3411 |

## 1.3 Warranty

---

Warranty is granted for a period of two years from the date of purchase. Defects as a result of material or manufacturing defects are eliminated free of charge if:

- The device is sent to the manufacturer free of charge.
- The proof of purchase is enclosed
- The device has been treated and used as intended.
- No foreign spare parts have been installed or interference has been made.

Excluded from the guarantee are damages caused by:



- Overvoltage at the inputs or incorrect connection
- Liquids spilled into the device or oxidation due to condensation
- Lightning strike

Not covered by the warranty are consequential costs and natural wear.

When asserting claims under warranty and warranty, a detailed description of the defect is essential. Detailed instructions facilitate and speed up the processing. Please understand that we cannot accept shipments that are not free.

## 1.4 Disclaimer

---

Both the compliance with the operating instructions and the conditions and methods for installation, operation, use and maintenance of the tank monitor TCS cannot be monitored by philippi electrical systems gmbh. Therefore, we assume no responsibility or liability for any loss, damage or expense resulting from improper installation or improper operation.

## 1.5 Quality assurance

---

During production and assembly, the devices undergo several checks and tests. Fabrication, checks and tests are carried out according to established protocols. Each device has its own serial number. Never remove the nameplate. The assembly and the test of all devices are carried out completely in our facilities.

## 2. Safety instructions

---



- It must not be changed on the device, otherwise it will go out CE mark
- The tank monitor may only be connected by qualified electricians.
- Disconnect the battery leads before connecting the tank monitor.
- Pay attention to the correct polarity of the batteries!
- The power supply to the monitor must be protected.

• **This device is not intended for use by children.**

The present installation and operating instruction is part of the component delivery. It must - well important for subsequent maintenance - well kept and passed on to any subsequent owners of the device.

### 3. Installation

#### 3.1. Monitor

Install the monitor in a protected, dry and well-visible place so that it can be read at any time. The cut-out is 87 x 65 mm, the required minimum depth is 35mm. On the back side there is a 11-pin terminal for the power supply of the monitor and the tank sensors.

On the back side, a software update can be uploaded to the monitor via a micro SD card.

The power supply of the monitor can be interrupted at any time without losing setup data.

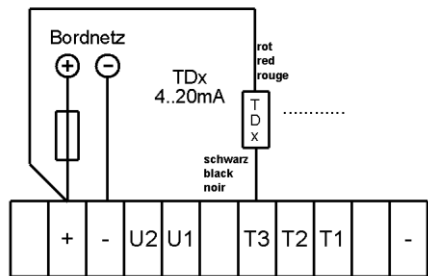
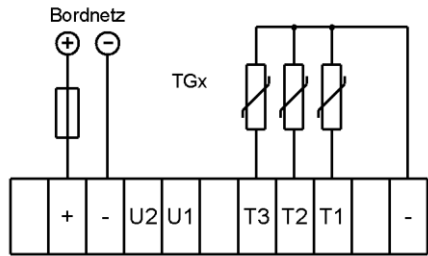

#### 3.2. Electrical Connection

Up to 3 tanks can be monitored simultaneously.

However, if fewer tanks are monitored, the first gauge will be connected starting at port TG 1 (for example, with 2 tankers, only ports TG 1 and TG 2 will be used).

Resistive sensors (e.g., TGT / TGW) and active tank sensors (e.g., TDS pressure probes) may be connected in mixed form.

The connection is made according to the adjacent diagram

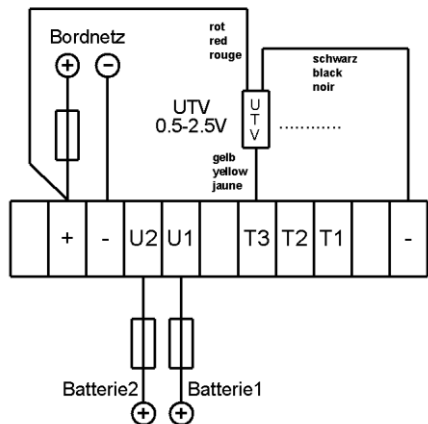

**ATTENTION:**

If the power supply (red line) of the ultrasonic sensor or the pressure sensor does not take place via the TCS, but directly via the DC on-board network, the supply line must be fused with a 1A fuse!

The negative lines of the tank sensors must be connected to the negative (-) terminal to avoid incorrect measurements.

## 4. Setup

To access the settings, please press the gear icon in the lower right corner of the main screen



### 4.1 Access (PIN) to setup

Subsequently, the query of the PIN, which is "1234" in the delivery state, appears.

After successful entry with subsequent confirmation "OK" will take you to the settings menu.



Es können durch Drücken des jeweiligen Symbols folgende Einstellungen vorgenommen werden:

1. Display settings
2. Name of batteries
3. Alarm settings
4. Tank settings

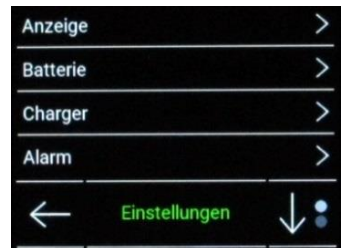

## 4.2 Display

After pressing the "Display" symbol, the adjacent image appears. The following settings can now be made:

- Language German / French / English
- Brightness max. 20 - 100%
- Brightness Auto ON / OFF
- Auto stand by OFF / x s / min.
- Change PIN
- Number of tanks 1-3 tanks



## 4.3 Alarms

A tank alarm is always indicated by the flashing of the associated tank symbol. A voltage alarm is always displayed in the battery icon. In addition, the alarm can be issued / configured as follows:

- optical display lighting flashes
- acoustically internal buzzer

The visual and audible alarm can always be acknowledged in advance by touching the screen, or can automatically be switched off after a definable time.

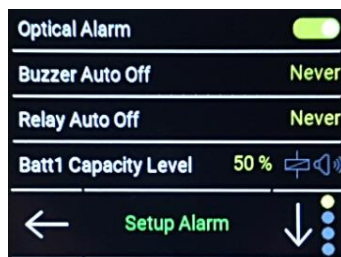

*Alarm options:*

### Tank alarms:

For each of the 3 tanks, an alarm threshold can be set individually. The following settings are possible:

- 0% alarm off
- 1..50% Empty alarm: if the level falls below the set value, an alarm is triggered.  
The alarm is delayed by 15s.
- 51 ... 99% Full alarm: if the level rises above the set value, an alarm is triggered.  
The alarm is delayed by 15s.

The alarm is automatically cancelled as soon as the value has changed by 5%.

### Battery voltage alarms

If a voltage > 1V is present at the terminal U1 or U2, this is reported as a battery. If the battery voltage drops or exceeds the set threshold value for 30 s, an alarm can be generated.

#### The following settings are possible in the alarm menu:

- Optical alarm                      lighting flickers (on / off)
- Alarm auto off                      0-255 sec (0 = always on)

The buzzer can be configured for individual alarms. Depending on the configuration, the alarm starts for the following alarm states and remains switched on until all pending alarms have been cancelled. If an alarm has been acknowledged and a new alarm is added, the buzzer will be reactivated.

Battery 1	Undervoltage	adjustable (9-24V)
	Overvoltage	adjustable (14-32V)
Battery 2	Undervoltage	adjustable (9-24V)
	Overvoltage	adjustable (14-32V)

The voltage alarms must necessarily be adapted for 24V batteries!

Tank	Tank 1	level adjustable, empty or full alarm
	Tank 2	level adjustable, empty or full alarm
	Tank 3	level adjustable, empty or full alarm

By briefly pressing the respective line, the audible alarm can be switched on or off. At long pressure (> 2s) the respective threshold value can be edited.

## 4.6 Settings for tanks:

The respective tank menu for the illustrated tanks can be accessed by pressing the key (arrow on the right):

In the tank menu, the volume, the tank type, the sensor type can be entered and an adjustment to the tank geometry can be made. When the resistance range (user R) is freely set, the ohm values for 0%, 25%, 50%, 75% and 100% are entered in this menu or the tank monitor can accept the resistance values for these levels at the push of a button.

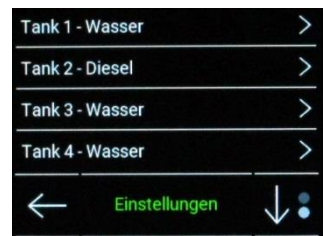

The same applies to tank sensors with a voltage output (sensor type: User U).

For the sensor type UTV 40/80, the tank depth is entered in this menu.

These settings are saved in the event of a power failure and are available again after restarting.



### 4.6.1 Tank type

For each tank, there are 5 different tank symbols to choose from: Water / Diesel / Gasoline / Black Water / Gray Water

### 4.6.2 Volumes

Enter the tank volume. The content is displayed in liters.

### 4.6.3 Tank sensors

Type of sensor	Tank sensor	Measuring range	Adaption of Geometry
TGX 10-180 (Ohm)	philippi TGT / TGW	10..180 Ohm	optional
240 - 33 (Ohm)	240...33 Ohm	active sensor not possible!	optional
User R	1 - 1000 Ohm	1 - 1000 Ohm	necessary
User V	0..10V	0..10V	necessary
UTV 40/80	philippi UTV 40/UTV 80	0,5..2,5 V	optional
TDS / User I	4 – 20mA	0-20mA	necessary
TRS	philippi TRS / RSW / DSW	Float switch	not available
Gobius4	Gobius 4 (1-4V)	4 Steps	not available

If the tank type does not match the sensor type used, either "----" will be displayed as a value or an incorrect value may be displayed.

#### 4.6.3.1 Sensor type TGX 10 – 180 (OHM)

For this setting you need a tank transmitter TGW (fresh water) or TGT (fuel) with a resistance range of 10 - 180 ohms (10 ohms = empty / 180 ohms = full). In the TRIM menu, the characteristic curve of the fuel gauge can be adapted to the tank geometry.

#### 4.6.3.2 Sensor type 240 - 33 (OHM)

For this setting you need a fuel gauge with a resistance range of 240 - 33 ohms (240 ohms = empty / 33 ohms = full). In the TRIM menu, the characteristic curve of the fuel gauge can be adapted to the tank geometry.



### 4.6.3.3 Sensor type User R

---

For this setting you need a passive fuel gauge with any resistance range between 1 - 1000 ohms. For the levels 0, 25, 50, 75 and 100%, the corresponding resistance values must now be entered in the TRIM menu.

**Tank sensor:** This setting only works with passive resistance tank sensors, not with capacitive tank sensors or active resistance sensors (eg philippi UTR)!!

### 4.6.3.4 Sensor type USER V

---

For this setting you need an active fuel gauge with a voltage range of 0 - 10 volts. For fill levels 0, 25, 50, 75 and 100%, the corresponding voltage values must now be entered in menu item TRIM.

The fabric setting is for UTV sensors 0,5V (empty) to 2,5V (full).

### 4.6.3.5 Sensor type UTV 40 / 80

---

For this setting you need the following ultrasonic sensors:



- Tank depth (plus optional spacer ring UTS)  
smaller / equal 40 cm: UTV40
- tank depth (plus optional spacer ring UTS)  
greater than 40 cm: UTV 80 (max Total depth: 80 cm)

The tank depth can then be entered in the SETUP menu with centimeter precision for each tank. After selecting the tank type UTV 40/80, the UTV type, the possibly spacer ring UTS and the tank depth of the tank are entered in the submenu.

For tank depths incl. Spacer ring smaller than or equal to 40 cm, a UTV 40 is required; above a UTV 80. When using a UTV 40, the adjustable range is always below 40cm



Only UTV40 or UTV80 ultrasonic sensors may be used!

### 4.6.3.6 Sensor type TDS:

---

For this setting you will need a fuel gauge with a current output 4-20mA (for example TDS200, TDN200, UTA). The calibration takes place in the menu TRIM, where the corresponding current measured values can be entered or determined for the fill levels 0, 25, 50, 75 and 100%.

### 4.6.3.7 Sensor type TRS/RSW/DSW:

For this setting you need a philippi TRS float switch (mounting on top of the tank) or philippi RSW / DSW (side mounting). The fuel gauge stays at 0% until the float switch goes through - the display goes to 100%. There is no series resistor necessary!

### 4.6.3.8 Sensor type GOBIUS4

The voltage output of the Gobius control unit must be connected to a tank inlet. The level is displayed in 4 steps. The internal settings of the Gobius system cannot be changed from the TCS. They have to be adjusted via the Gobius panel.

## 4.6.4 Trim

To adapt the level indicator to a non-rectangular tank geometry, you have the option of adjusting the characteristic curve. The respective default settings from the selected encoder type can be adapted to individual conditions. For the tank types User R, User U, TDS this is absolutely necessary:

#### **Method 1 (Tank is filled step by step):**

the probe is in the empty tank. In the setup, you go to the setting value for 0% and read the measured value at the bottom center and enter 0% in the Level field. Then fill the tank to 25% and enter him in the field Level 25%. Analogously, proceed with the values 50%, 75%, 100%.

This method has the advantage that even if the tank shape is unusual, the content will be displayed correctly.

Level 0 %	10 Ohm
Level 25 %	45 Ohm
Level 50 %	100 Ohm
Level 75 %	150 Ohm
←	Actual Value 1000 Ohm
	↓

#### **Method 2 (installation eg TDS200 with full fuel tank):**

the probe is outside the tank. In the setup, you go to the setting value for 0% and read the measured value at the bottom center and enter 0% in the Level field.

Then you install the probe and read off the below measured value and enter it in the field Level 100%. To get the values for 25%, 50% and 75%, you must first divide the difference between the values 0% and 100% by 4. Add this value to the value at 0% - this gives you the input value for 25%. By further additions you get the values for 50% and 75%.

These values can be entered in the settings for 25%, 50% and 75%.

#### **Method 3:**

You know the values for 0%, 25%, 50%, 75% and 100%? Then enter these values directly in the corresponding settings.

## 5. Operation

The tank screen shows the individual tank levels. The measurement takes place automatically after switching on the monitor and is queried every 5s. The measured values are displayed in the form of a bar chart. By pressing the tank symbol you can switch between the display in %, in litres or without further display. If "----" appears above the associated tank, the measured value of the associated tank sensor is outside the expected value or no sensor is connected.

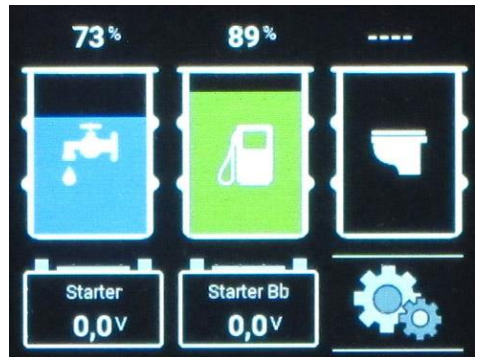

**The lower button on the right calls up the setup:**

**SETUP:** The settings of the system can be made here. See Chapter 4.

Up to two battery voltages of the batteries appear in the lower part of the screen. The names and associated voltage alarm thresholds can be adjusted in the settings.

## 6. Tips and tricks

If the indication in the display is not correct, always check the tank sensors and their supply lines first, as these are usually the cause of the error.

The adjustment menu is helpful as you can read off the current measured value of the tank sensor there and draw conclusions about the correct function.

## 7. Software Update

To update the battery tank monitor software, a micro SD card is required. After receiving the software, the file must be copied to the previously empty micro SD card (without folder, top level). To update, insert the SD card into the SD card slot on the back of the monitor and disconnect the power supply from the battery monitor. Then the power is turned on and the screen shows that new software has been detected and installed automatically. During the update process the progress is displayed. If the monitor starts normally after inserting the SD card, no SD card has been detected or the software is up-to-date.

---

## 8. Technical data

---

Supply voltage	DC 8-32 V
Current consumption monitor without tank sensor	60 mA at max. display brightness, 5 mA in sleep mode
Measuring range U1	0-35V, resolution 30mV, accuracy 0,25%
Measuring range U2	0-35V, resolution 30mV, accuracy 0,25%
Dimensions monitor	L 105 x W 105 x D 40 mm

---

## 9. Declaration of conformity

---

This device complies with the requirements of the EU directives:



2014/30 / EC "Electromagnetic compatibility"

Immunity EN 61000-6-1

Emitted interference EN 61000-6-3

The conformity of the device is confirmed by the CE mark.

---

## 10. Disposal instructions

---



When disposing of this device, observe the applicable local regulations and use the collection services / points for waste electrical and electronic equipment.

Sie die Sammeldienste/-stellen für Elektro-/Elektronik-Altgeräte.